

YS-ZB 3246 Semi Auto -Shrink Wrapping Machine

Product code: 36MC3246ST



Features and Benefits:

- Simplified heat-shrinking wrapper
- High Performance
- Ease of use and maintenance
- Advanced control
- Working Cycle electronically controlled by contactors
- Setting to start shrinking when sealing is completed
- Hold-down solenoid included and adjustable – Hood remains closed until cycle ends
- Re-opening system through gas spring

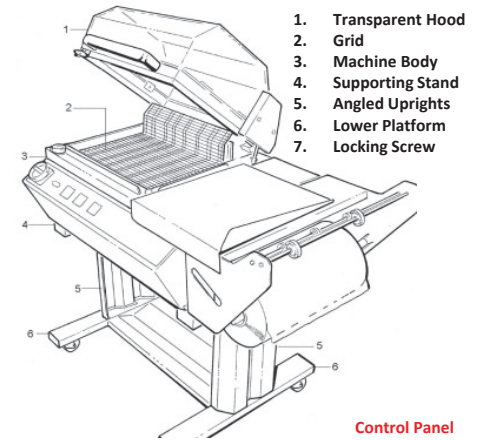

1. Transparent Hood
2. Grid
3. Machine Body
4. Supporting Stand
5. Angled Uprights
6. Lower Platform
7. Locking Screw

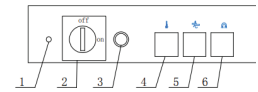

- Control Panel**
1. Power Indicator
 2. Main Power Switch
 3. Switch – Sealing/Shrink
 4. Thermoregulator
 5. Sealing timer
 6. Magnet Timer

Specifications:	
Model:	YS-ZB 3246
Power Supply:	Single Phase - 220V
Max Power:	2,1 KW's
Overall Dimensions:	1120mm x 680mm x 1200mm
Table Height:	920mm (with stand)
Stand Weight:	15 Kg's
Machine Weight:	71 Kg's
Edge Sealing Range:	320mm x 460mm
Packing Speed:	4-8/min
Max Product Height:	200mm
Sealing Method:	Bottom Blade
Roll Max Outer Diameter:	250mm x 470mm

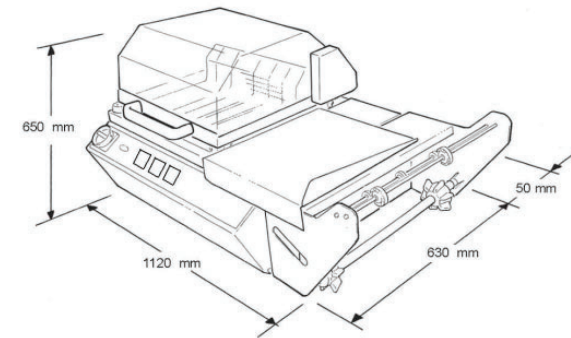

Works with POF – Polyolefin film and low micron LLDPE Shrink film Available at Bidvest Afcom

