

YS-ZB 3246 Semi Auto -Shrink Wrapping Machine

Product code: 36MC3246ST



Features and Benefits:

- Simplified heat-shrinking wrapper
- High Performance
- Ease of use and maintenance
- Advanced control
- Working Cycle electronically controlled by contactors
- Setting to start shrinking when sealing is completed
- Hold-down solenoid included and adjustable – Hood remains closed until cycle ends
- Re-opening system through gas spring
- **Uses minimal single-use plastic whilst providing maximum capability**

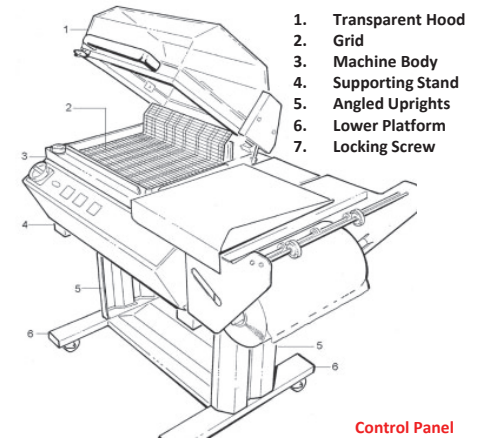

1. Transparent Hood
2. Grid
3. Machine Body
4. Supporting Stand
5. Angled Uprights
6. Lower Platform
7. Locking Screw

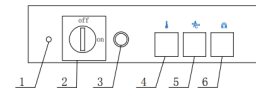

- Control Panel**
1. Power Indicator
 2. Main Power Switch
 3. Switch – Sealing/Shrink
 4. Thermoregulator
 5. Sealing timer
 6. Magnet Timer

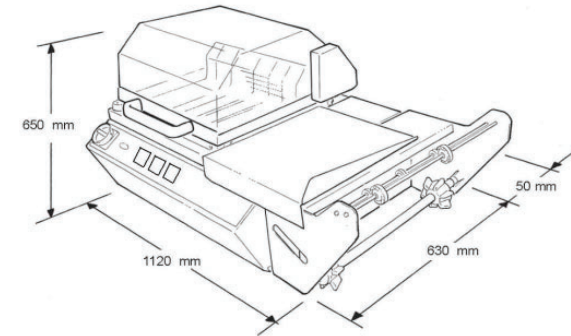

| Specifications: | |
|--------------------------|-------------------------|
| Model: | YS-ZB 3246 |
| Power Supply: | Single Phase - 220V |
| Max Power: | 2,1 KW's |
| Overall Dimensions: | 1120mm x 680mm x 1200mm |
| Table Height: | 920mm (with stand) |
| Stand Weight: | 15 Kg's |
| Machine Weight: | 71 Kg's |
| Edge Sealing Range: | 320mm x 460mm |
| Packing Speed: | 4-8/min |
| Max Product Height: | 200mm |
| Sealing Method: | Bottom Blade |
| Roll Max Outer Diameter: | 250mm x 470mm |

Works with POF – Polyolefin film and low micron LDPE Shrink film Available at Bidvest Afcom

