

# YS-ZB 4255 Semi Auto - Shrink Wrapping Machine

Product code: 36MC4255ST



## Features and Benefits:

- Simplified heat-shrinking wrapper
- High Performance
- Ease of use and maintenance
- Advanced control
- Working Cycle electronically controlled by contactors
- Setting to start shrinking when sealing is completed
- Hold-down solenoid included and adjustable – Hood remains closed until cycle ends
- Re-opening system through gas spring
- Uses minimal single-use plastic whilst providing maximum capability

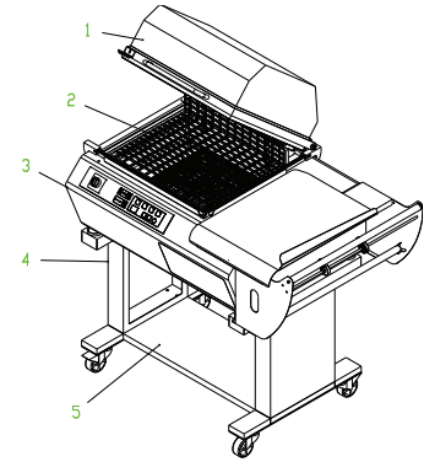

1. Transparent Hood
2. Grid
3. Machine Body
4. Supporting Stand
5. Lower Platform

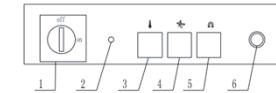

- Control Panel**
1. Main Power Switch
  2. Power Indicator
  3. Thermoregulator
  4. Sealing timer
  5. Magnet Timer
  6. Switch – Sealing/Shrink

Specifications:	
Model:	YS-ZB 4255
Power Supply:	Single Phase - 220V
Max Power:	3,5 KW's
Overall Dimensions:	1370mm x 680mm x 1200mm
Table Height:	920mm (with stand)
Stand Weight:	22 Kg's
Machine Weight:	100 Kg's
Edge Sealing Range:	420mm x 550mm
Packing Speed:	4-8/min
Max Product Height:	200mm
Sealing Method:	Bottom Blade
Roll Max Outer Diameter:	250mm x 600mm

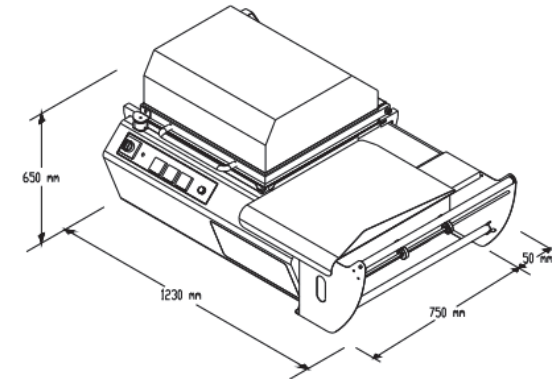

Works with POF – Polyolefin film and low micron LDPE Shrink film Available at Bidvest Afcom

