

YS-ZB 6084ST Semi Auto - Shrink Wrapping Machine

Product code: 36MC6084ST



Features and Benefits:

- Simplified heat-shrinking wrapper
- High Performance
- Ease of use and maintenance
- Advanced control
- Working Cycle electronically controlled by contactors
- Setting to start shrinking when sealing is completed
- Hold-down solenoid included and adjustable – Hood remains closed until cycle ends
- Re-opening system through gas spring
- **Uses minimal single-use plastic whilst providing maximum capability**

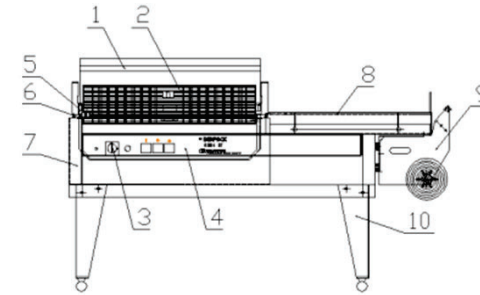

1. Transparent Hood
2. Grid
3. General Switch
4. Control Panel
5. Magneto
6. Start Cycle Device
7. Machine Body
8. Working Table
9. Film Holder
10. Machine Foot

Control Panel

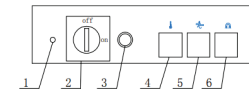

1. Power Indicator
2. Main Power Switch
3. Switch – Sealing/Shrink
4. Thermoregulator
5. Sealing timer
6. Magnet Timer

Specifications:	
Model:	YS-ZB 6084
Power Supply:	Three Phase - 380V
Max Power:	7 KW's
Overall Dimensions:	1940mm x 950mm x 1200mm
Table Height:	920mm (with stand)
Stand Weight:	-
Machine Weight:	180 Kg's
Edge Sealing Range:	600mm x 840mm
Packing Speed:	4-8/min
Max Product Height:	200mm
Sealing Method:	Bottom Blade
Roll Max Outer Diameter:	250mm x 800mm

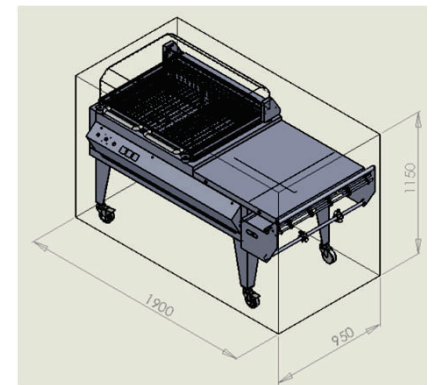

Works with POF – Polyolefin film and low micron LDPE Shrink film Available at Bidvest Afcom

