

YS802 – Random Carton Sealer – Water Activated Tape

Product code: 217200



Features and Benefits:

- Automatic adjustable width and height (Random Carton)
- Ease of use and maintenance
- Advanced controls – One Touch
- Steel Frame – Powder Coated – Heavy duty
- Up to 9 Preset carton sizes
- Emergency Stop
- Low Noise
- Adjustable Table height 700mm up to 820mm
- Tape Jamming warning
- Tape finished warning

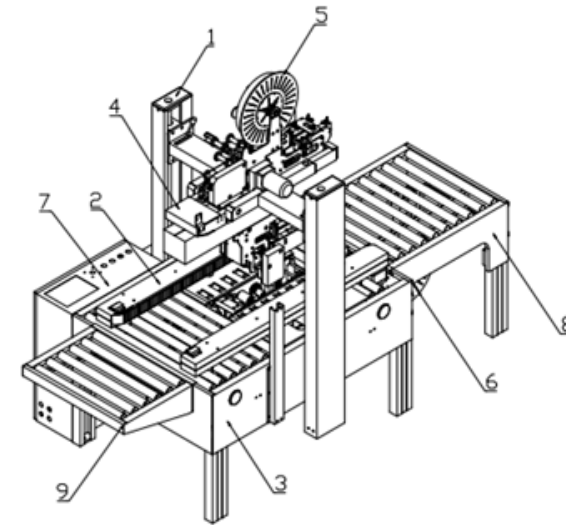

- 1. Upright Post Unit
- 2. Side Power Device
- 3. Machine Frame
- 4. Head Unit Frame
- 5. Upper Taping Head
- 6. Lower Taping Head
- 7. Electrical Cabinet
- 8. Worktable
- 9. Connected Worktable

Specifications:

Model:	YS-802
Power Supply:	Single Phase - 220V
Max Power:	2.52 KW's
Overall Dimensions:	1932mm x 1173mm x 1610mm
Shipping Weight:	280Kg's
Tape roll Capacity:	Up to 300mm outside diameter on a roll 48mm/60mm/70mm
Dispensing Speed:	1200mm per minute
Water Bottle Capacity:	1.5 Liters x 2 (Top and Bottom Head)
Electrical:	Schneider PLC and Touch Screen P+F Photo Eye, Schneider Electric
	Airtec Pneumatic

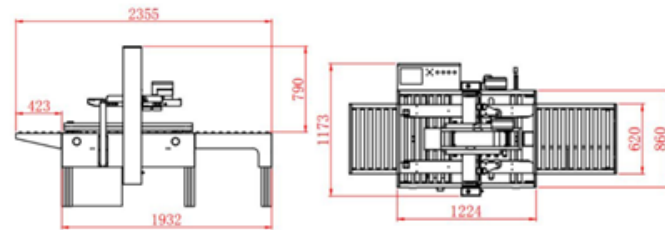
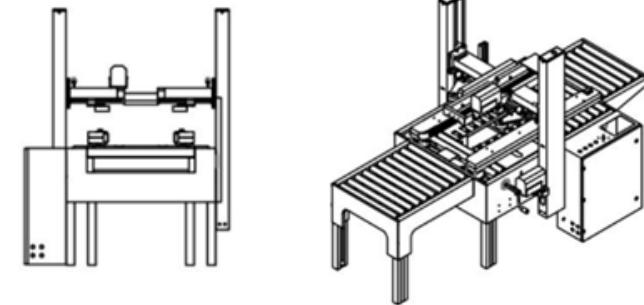

Works with WAT – Water Activated Tape – Reinforced and Plain (Print up to 8 Colour)
Manufactured by Bidvest Afcom

