

## Features & Benefits

- Increased throughput & improved efficiency
- No manual labour required
- Can take various pack sizes
- Minimal maintenance required
- Temperature control panel

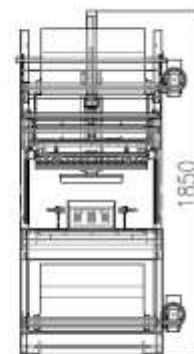

Model	YS-ZB-1
Motor Power	380V, 50Hz, 2kW – 3 Phase
Required Air Pressure	5-8kg/cm <sup>2</sup>
Packaging Speed	10-15 packages/min (dependent on products)
Work Table Height	750 -850mm
Machine Size (L x W x H)	1215mm x 985mm x 1850mm
Sealing Knife	Stainless Steel, Teflon Spray
Sealing Temperature	150-180°C
Maximum Package Size (L x W x H)	600mm x 400mm x 500mm
Film Specifications	PE Film Shrinking: 125°C Film Thickness 0.04 – 0.08mm Film Width Based on Products

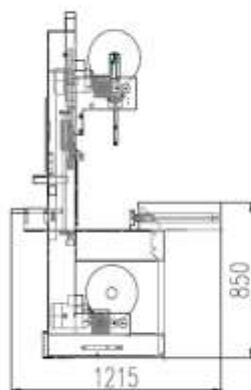
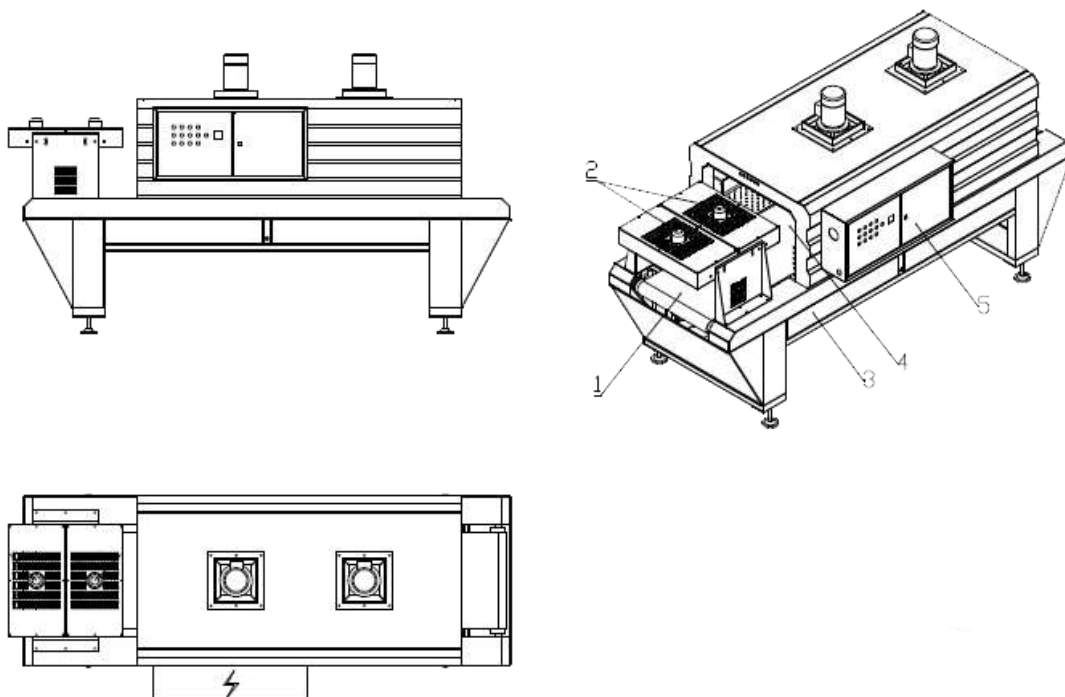

Model	ZJ2 (Tunnel)
Power Voltage	380V (1±10%), 50Hz, 28kW
Transporting Speed	0-18m/min
Main Material	Q235-A carbon steel
Work Table Height	750 –Custom Made
Conveyor Belt	Pole Type
Heater	12pcs, 2000W/pc
Temperature	0-400°C
Use Temperature	150-180°C
Film Specifications	PE Film, POF, PVC Shrink Filming Film Thickness: 60-100μ (PE) Film Traverse Shrinkage Rate: 30-40% (PE) Film Longitudinal Shrinkage Rate: 60-70% (PE)
Furnace Chamber Size (L x W x H)	2100mm x 1350mm x 1345mm (can be custom made) 1500mm x 950mm x 550mm (can be custom made)
Machine Weight	350Kg
Noise	≤75dB (A)
Environmental Conditions	Humidity ≤90%, Temperature, 0-40°C

