

Combination tools function as tensioners, sealers, and often cutters as well. They save time by eliminating the handling of separate tools. But weighing more than such tools, they should be placed as close as possible to the position where they will be used. Seal-feed combination tools carry a stack of seals in a magazine for fast, easy loading.

**Manual seal-feed**

Manually operated seal-feed combination tools include the AH, AL, and AM series models.

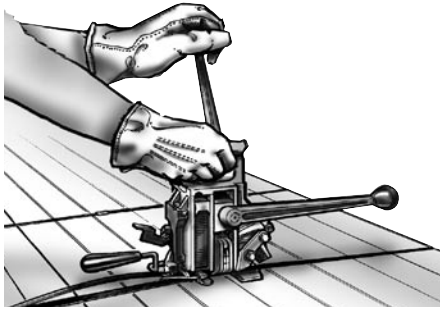

**Manual sealless**

The SCM and SCMH sealless combination tools require no metal seals, saving time and money. Production interruptions for reloading are eliminated, along with the purchasing, inventorying and loading of seals.

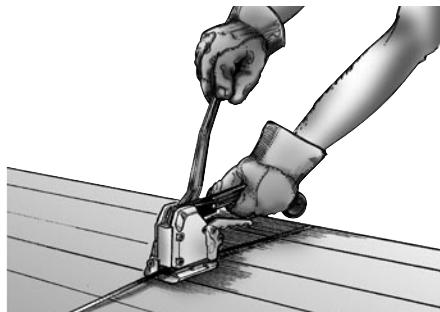

**Pneumatic seal-feed**

Using applied air pressure as a power source, pneumatic seal-feed combination tools quickly and effortlessly tension, seal, and cut the strapping. These tools include the AHP and the AMP.

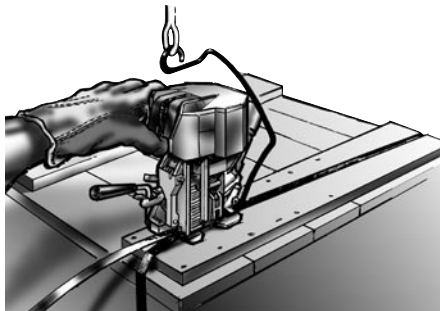

**Pneumatic sealless**

Pneumatic sealless combination tools include the SLP and the SPC.

Model	Part Number	Strap Size				Strap Type	Seal Name	Joint Type	Weight	
		Width		Thickness					lbs	kg
		inch	mm	inch	mm					
<b>Manual seal-feed</b>										
AL-38	023380	3/8	9.5	0.017-0.020	0.43-0.51	Apex Plus	38 AL	Double Notch	8	3.6
AL-12	023300	1/2	12.7	0.017	0.43		12 AL			
AM-12	023230	1/2	12.7	0.017-0.023	0.43-0.58	Apex Plus, Magnus	12 AMP	Double Notch	14	6.4
AM-58	023220	5/8	15.9	0.017-0.023	0.43-0.58		58/34 AMP			
AM-34*	023200	3/4	19.0	0.017-0.025	0.43-0.64					
AH-114	015700	1-1/4	31.8	0.031-0.035	0.79-0.89	Magnus	114 A	DRN**	25	11.3

<b>Manual sealless</b>										
SCM-12	424350	1/2	12.7	0.017-0.023	0.43-0.58	Apex Plus, Magnus	Sealless	3 Key	8.4	3.8
SCM-58	424358	5/8	15.9	0.017-0.023	0.43-0.58					
SCM-34	424334	3/4	19.0	0.017-0.025	0.43-0.64					
SCMH-58	424510	5/8	15.9	0.020-0.023	0.51-0.58	Apex Plus, Magnus	Sealless	3 Key	11	5
SCMH-34	424500	3/4	19.0	0.023-0.031	0.58-0.79					

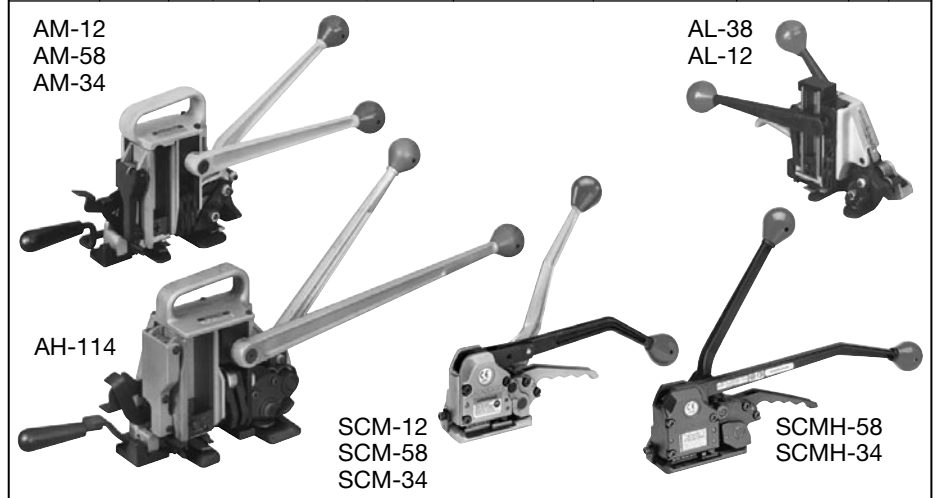

<b>Pneumatic seal-feed</b>										
AMP-1-12	024780	1/2	12.7	0.020-0.023	0.51-0.58	Magnus	12 AMP	Double Notch	22	10
AMP-1-58	024770	5/8	15.9	0.020-0.023	0.51-0.58	Apex Plus, Magnus	58/34 AMP		22	10
AMP-1-34	024760	3/4	19.0	0.020-0.025	0.51-0.64				22	10
AHP-34	023700	3/4	19.0	0.031	0.79	Magnus	34 MNT		40	18.1
AHP-2-114	015650	1-1/4	31.8	0.025-0.035	0.64-0.89	Magnus	114 A	DRN**	40	18.1

<b>Pneumatic sealless</b>										
SLP-12	422350	1/2	12.7	0.017-0.023	0.43-0.58	Apex Plus, Magnus	Sealless	3 Key	15	6.4
SLP-58	422355	5/8	15.9	0.017-0.023	0.43-0.58					
SLP-34	422360	3/4	19.0	0.017-0.025	0.43-0.64					
SPC-3431	422446	3/4	19.0	0.025-0.031	0.64-0.79	Magnus	Sealless	4 Key	24	10.8
SPC-114	423125	1-1/4	31.8	0.025-0.031	0.64-0.79	Magnus	Sealless	4 Key	37	16.8



\*A conversion kit is available to accommodate 0.031 strapping (Part No. 306815). \*\*Double Reverse Notch

## For steel strapping

### Pneumatic push-type

Pneumatic push-type combination tools, including the PNSC and PRH-Series models, are used with push-type seals on irregular-shaped packages. Air power tensions, seals and cuts the strapping.

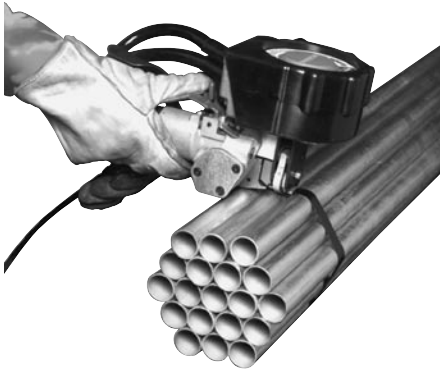

Model	Part Number	Strap Size				Strap Type	Seal Name	Joint Type	Weight	
		Width		Thickness					lbs	kg
		inch	mm	inch	mm					
<b>Pneumatic push-type</b>										
PNSC 2-12	422495	1/2	12.7	0.017-0.023	0.43-0.58	Apex Plus, Magnus	12 SPC	Single		
PNSC 2-58	422496	5/8	15.9	0.017-0.023	0.43-0.58		58 SPC	Reverse	9.5	4.3
PNSC 2-34	422497	3/4	19.0	0.017-0.025	0.43-0.64		34 PNSC	Notch		
PRHM-34	306700	3/4	19.0	0.025-0.031	0.64-0.79	Magnus	34 HOC	Double	16	7.3
PRHR-34	424234	3/4	19.0	0.025-0.031	0.64-0.79	Magnus	34 HOC	Reverse	34	15.4
PRHR-114	423570	1-1/4	31.8	0.025-0.035	0.64-0.89		114 P	Notch	34	15.4



## Pneumatic Tool Accessories

### For steel strapping

### Pneumatic tool accessories

All new Signode pneumatic tools are supplied with a quick-disconnect plug. A filter and regulator are needed with all Signode pneumatic sealers. A filter-regulator-lubricator is needed with all pneumatic tools. These additional fittings and air hoses are available from Signode to help provide optimum operation.

Recommended air hose for pneumatic tools: 10' x 1/2" (3.0m x 12mm) i.d. **(Part No. 424774)**

Note: Use light hydraulic oil in lubricator, such as Non-Fluid Oil No. LS-1236 (Part No. 008556) or equivalent.

Filter-Regulator-Lubricator assembly **(Part No. 424773)**

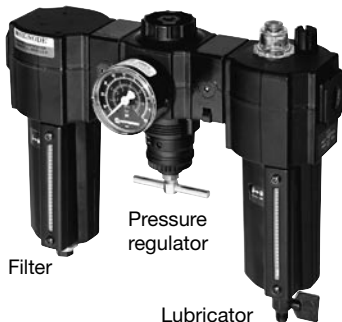

### Recommended air line piping

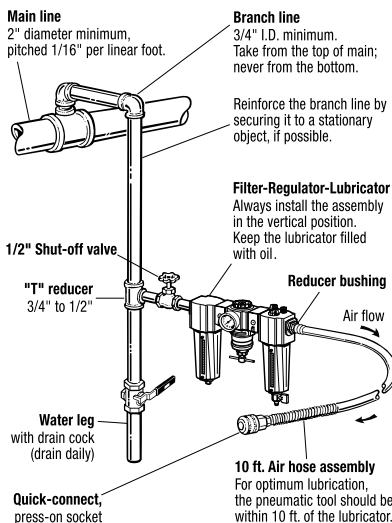

Quick-disconnect socket 3/8" (9.5mm) i.d. **(Part No. 008569)**. Lubricator fitting for hose connection.



Quick-disconnect socket 1/4" (6.4mm) i.d. **(Part No. 020706)**. Hose fitting for tool connection.



Quick-disconnect plug 1/4" (6.4mm) i.d. **(Part No. 008568)**. Hose fitting for lubricator connection.



Quick-disconnect plug 1/4" (6.4mm) i.d. **(Part No. 020704)**. Tool fitting for hose connection.



Y-fitting **(Part No. 008574)** for operating two tools simultaneously.



Regulator mounting bracket **(Part No. 071982)**