

Tensioners

Signode pneumatic tensioners take most of the effort out of strapping large or compressible packages. They also make tensioning uniform and precise through adjustment of the air pressure regulator.

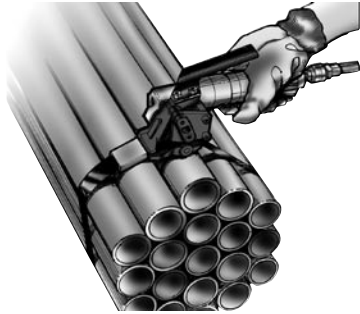

All pneumatic tensioners, except the WP-2, have unlimited strap take-up. All pneumatic tensioners are furnished with a quick-disconnect plug.

It is essential that an air filter-regulator-lubricator assembly (Part No. 424773) be installed ahead of the tool on the air line.

Sealers

Signode pneumatic sealers let compressed air do most of the work. They are used to achieve high production on heavy strapping, especially when seals are in awkward positions or whenever productivity must be maximized.

These labor-saving sealers come in two basic styles. Those featuring pistol grips are lightweight for easy one-hand operation. Diaphragm types are for heavier-duty applications, such as carloading.

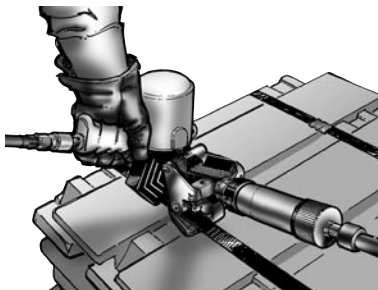

All pneumatic sealers are furnished with a quick-disconnect plug. An air filter and regulator are necessary. A lubricator in the air line is not required.

* Three seals are required per joint.

Model	Part Number	Strap Size				Strap Type	Strap Finish	Maximum Strap Tension		Weight	
		Width		Thickness				lbs	N	lbs	kg
		inch	mm	inch	mm						
Feedwheel tensioners											
FN-114T	008810	3/4-1-1/4	19.0-31.8	.031-.044	0.79-1.12	Magnus	Painted & Waxed	3,000	13 350	24	10.9
HN-1-114	027050	1-1/4	31.8	.029-.044	0.74-1.12	Magnus	Painted & Waxed	2,800	12 454	18	8.2



Push-type tensioner											
PN-2-114	423500	3/4-1-1/4	19.0-31.8	.020-.044	0.51-1.12	Magnus	Painted & Waxed	1,600	7 120	8.1	3.7



Windlass tensioner											
WP-2	023070	2	50.8	.044	1.12	Magnus	Painted & Waxed	8,000	35 590	23	10.4



Model	Part Number	Strap Size				Seal Name	Joint Type	Weight	
		Width		Thickness				lbs	kg
		inch	mm	inch	mm				

Sealers									
RCNS2-34	424200	3/4	19.0	0.025-0.031	0.64-0.79	34 HOC, 34 SHOC,	Single Rev. Notch	9	4.1
RCNS2-114	424125	1-1/4	31.8	0.025-0.031	0.64-0.79	114 OF, 114 P, 114 TO	Single Rev. Notch	9	4.1
N-1444-50LSH	024271	1-1/4	31.8	0.044-0.050	1.12-1.27	117 HDG OF	Double Crimp	22	10
N-1457-LSH-2A*	423810	1-1/4	31.8	0.050-0.057	1.27-1.45	117 HDG OF	Double Crimp	32	14.5
NSP-1435	015600	1-1/4	31.8	0.031-0.035	0.79-0.89	107 DG, 107 DG OF	Single Crimp	9	4.1
NS-250-65L	014360	2	50.8	0.044-0.050	1.12-1.27	208 DG	Single Crimp	22	10

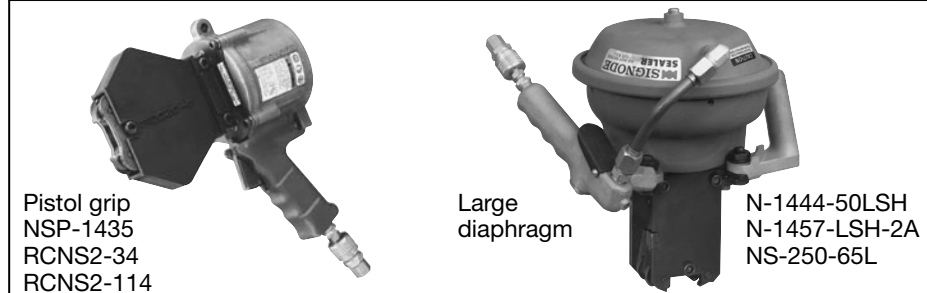

For steel strapping

Pneumatic tool accessories

All new Signode pneumatic tools are supplied with a quick-disconnect plug. A filter and regulator are needed with all Signode pneumatic sealers. A filter-regulator-lubricator is needed with all pneumatic tools. These additional fittings and air hoses are available from Signode to help provide optimum operation.

Recommended air hose for pneumatic tools: 10' x 1/2" (3.0 m x 12 mm) i.d. **(Part No. 424774)**

Note: Use light hydraulic oil in lubricator, such as Non-Fluid Oil No. LS-1236 (Part No. 008556) or equivalent.

Filter-Regulator-Lubricator assembly **(Part No. 424773)**

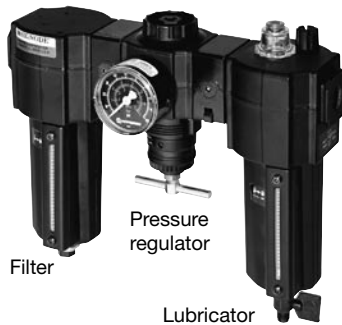

Recommended air line piping

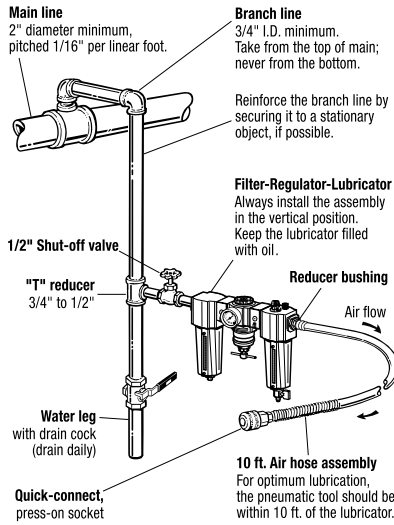

Quick-disconnect socket 3/8" (9.5 mm) i.d. **(Part No. 008569)**. Lubricator fitting for hose connection.



Quick-disconnect socket 1/4" (6.4 mm) i.d. **(Part No. 020706)**. Hose fitting for tool connection.



Quick-disconnect plug 1/4" (6.4 mm) i.d. **(Part No. 008568)**. Hose fitting for lubricator connection.



Quick-disconnect plug 1/4" (6.4 mm) i.d. **(Part No. 020704)**. Tool fitting for hose connection.



Y-fitting **(Part No. 008574)** for operating two tools simultaneously.



Regulator mounting bracket **(Part No. 071982)**